

Ein-Aus- (oben) und Wechselschalter (unten): Der m84 bietet vier Wechselschalter, die sich auch als Ein-Aus-Schalter verwenden lassen.

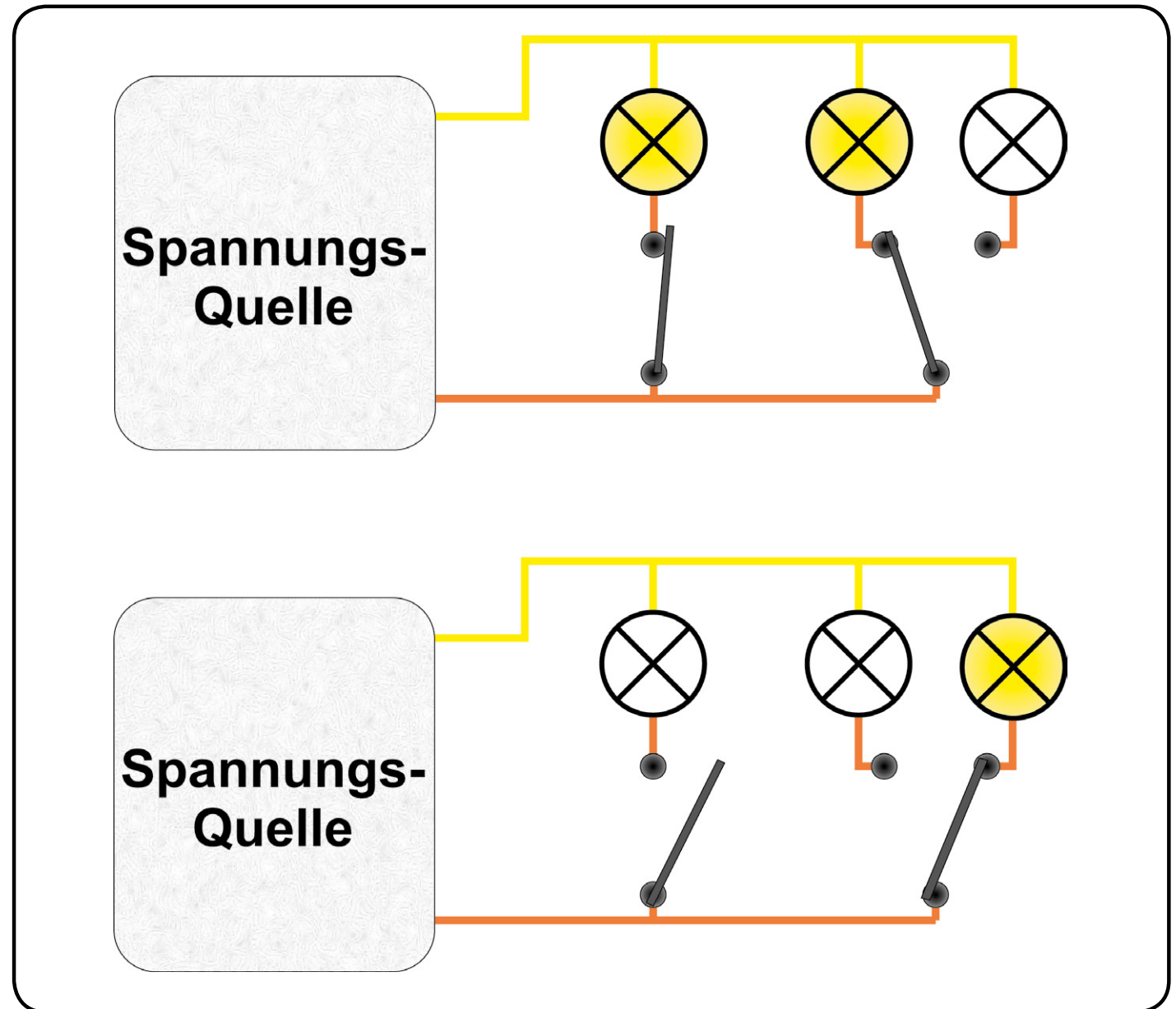

Der m84 ersetzt
in verdeckten
Bereichen die
Funktionalität von
Signalen.

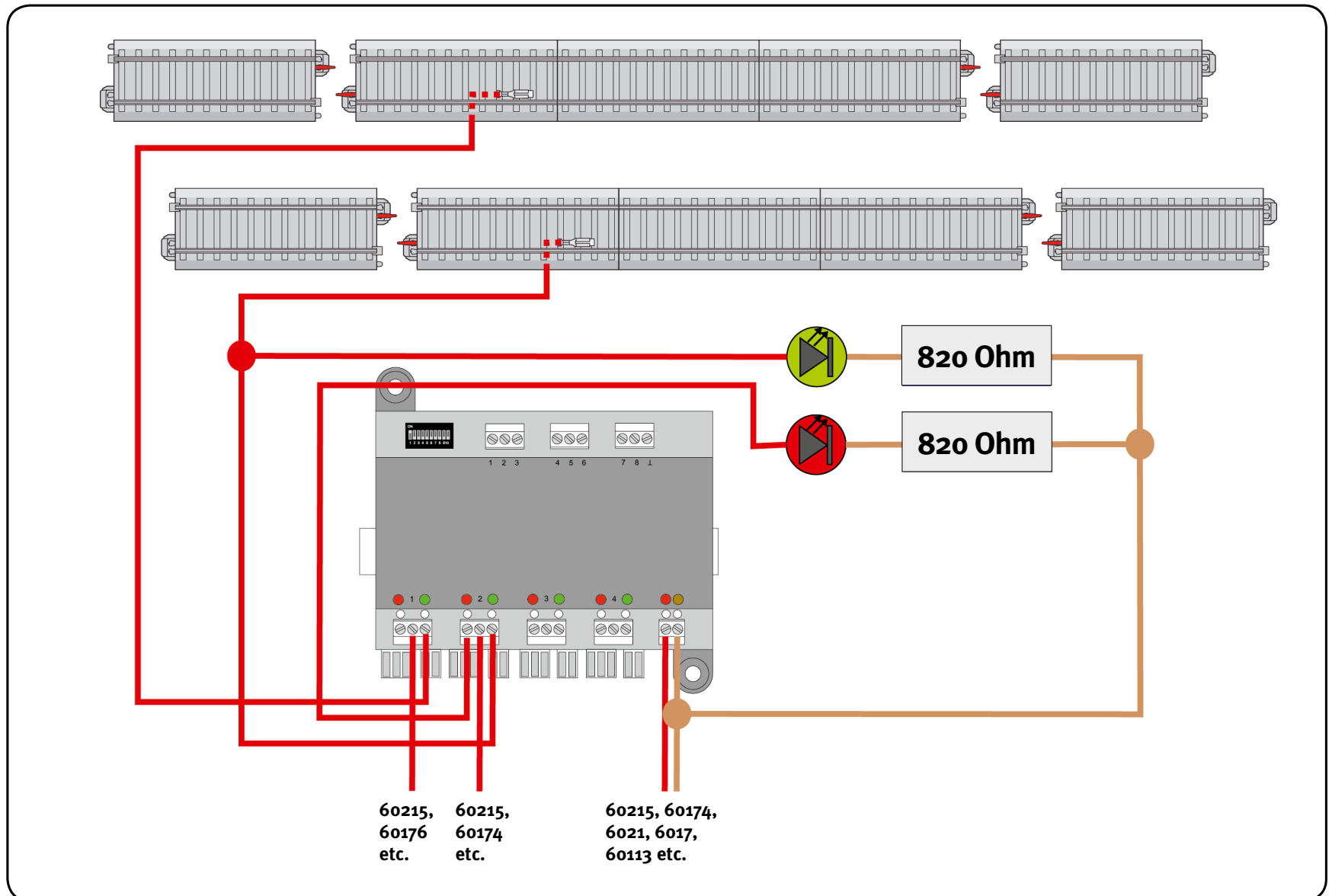

Der m84 schaltet nicht nur Straßen- und Prellbocklampen, sondern wirkt mit einem Trafo auch als Dimmer.

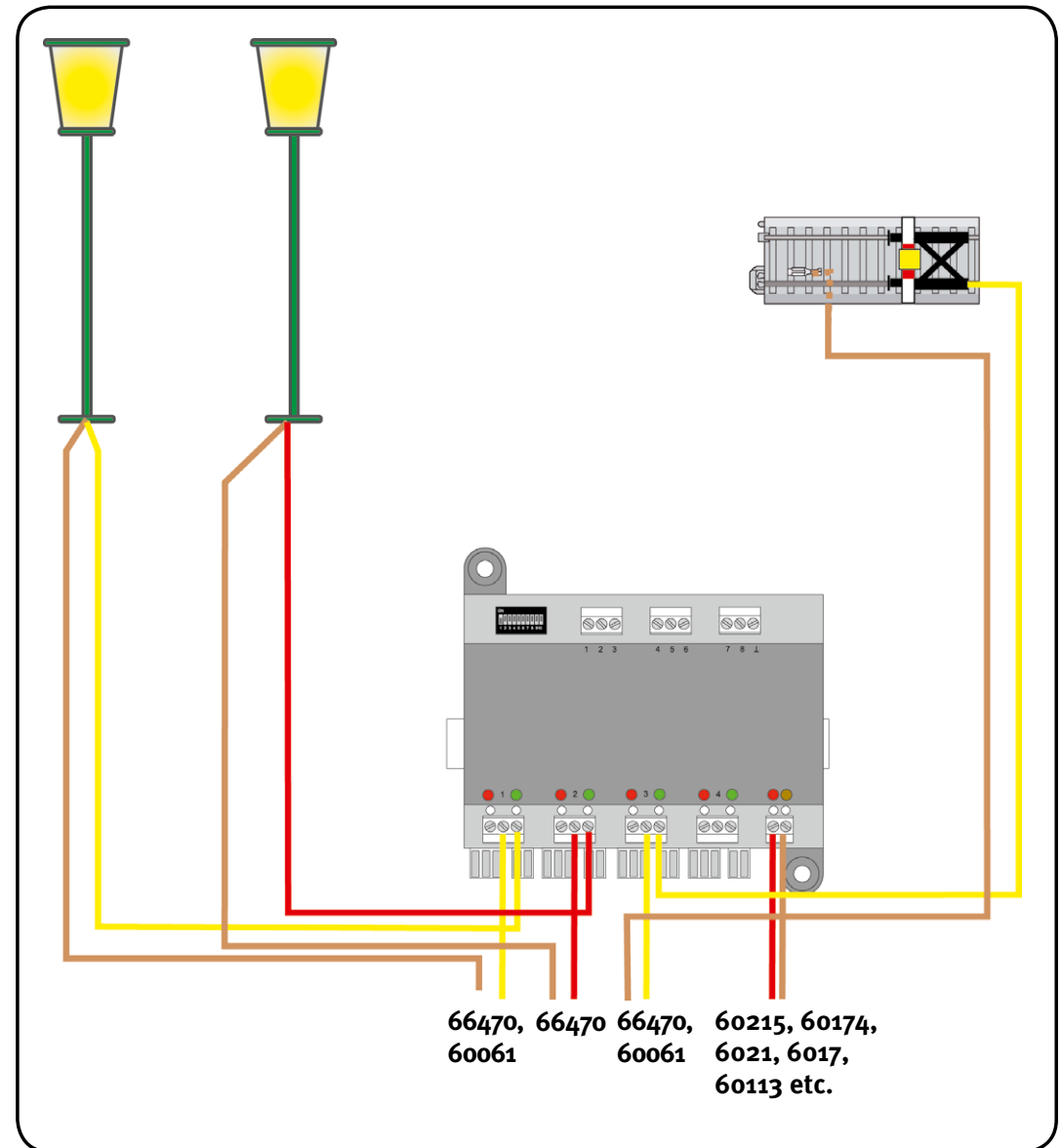

Der m84 steuert sogar Gleichstrommotoren. Wer die Drehrichtung ändern will, schaltet zwei Dioden ein.

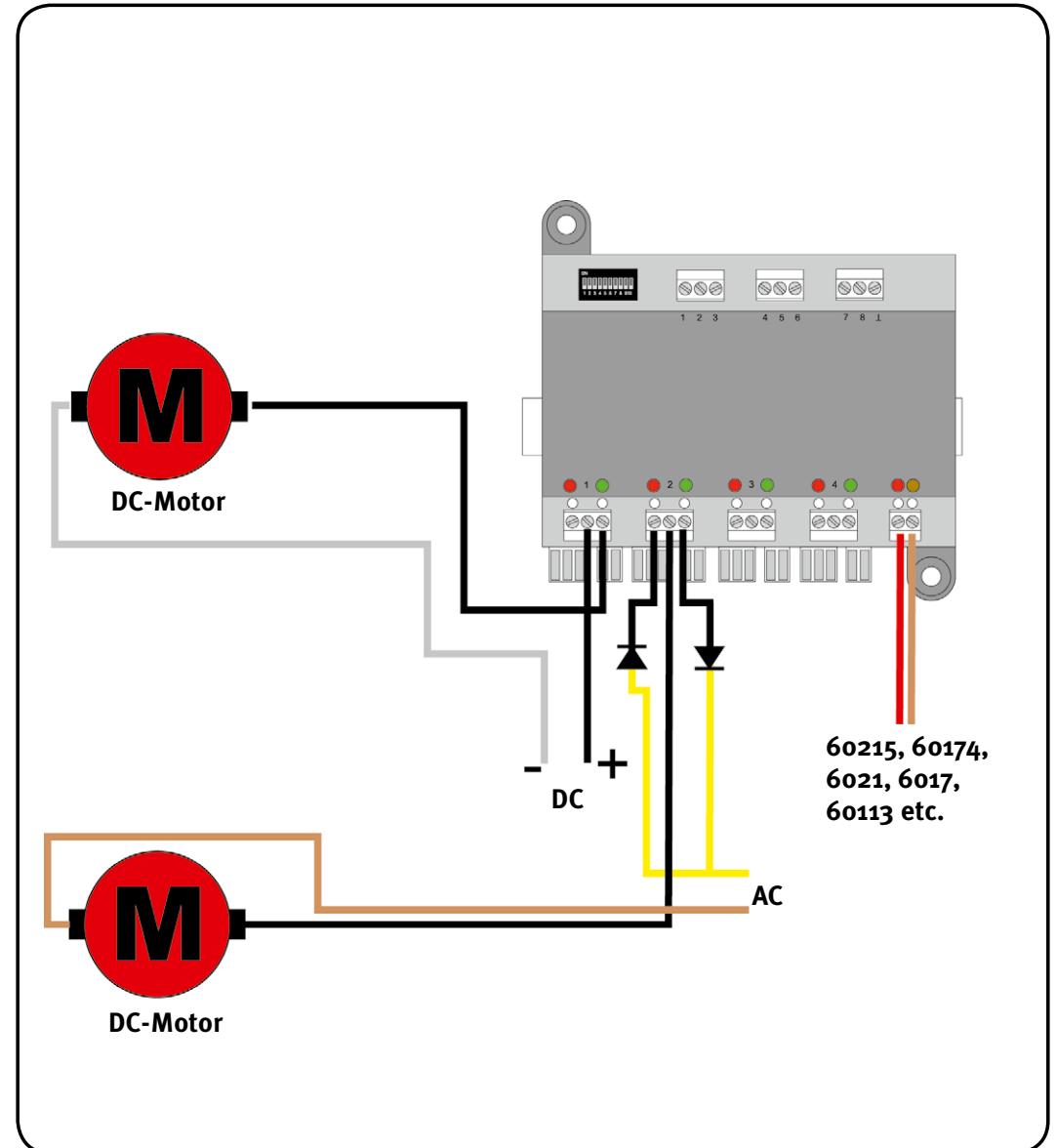

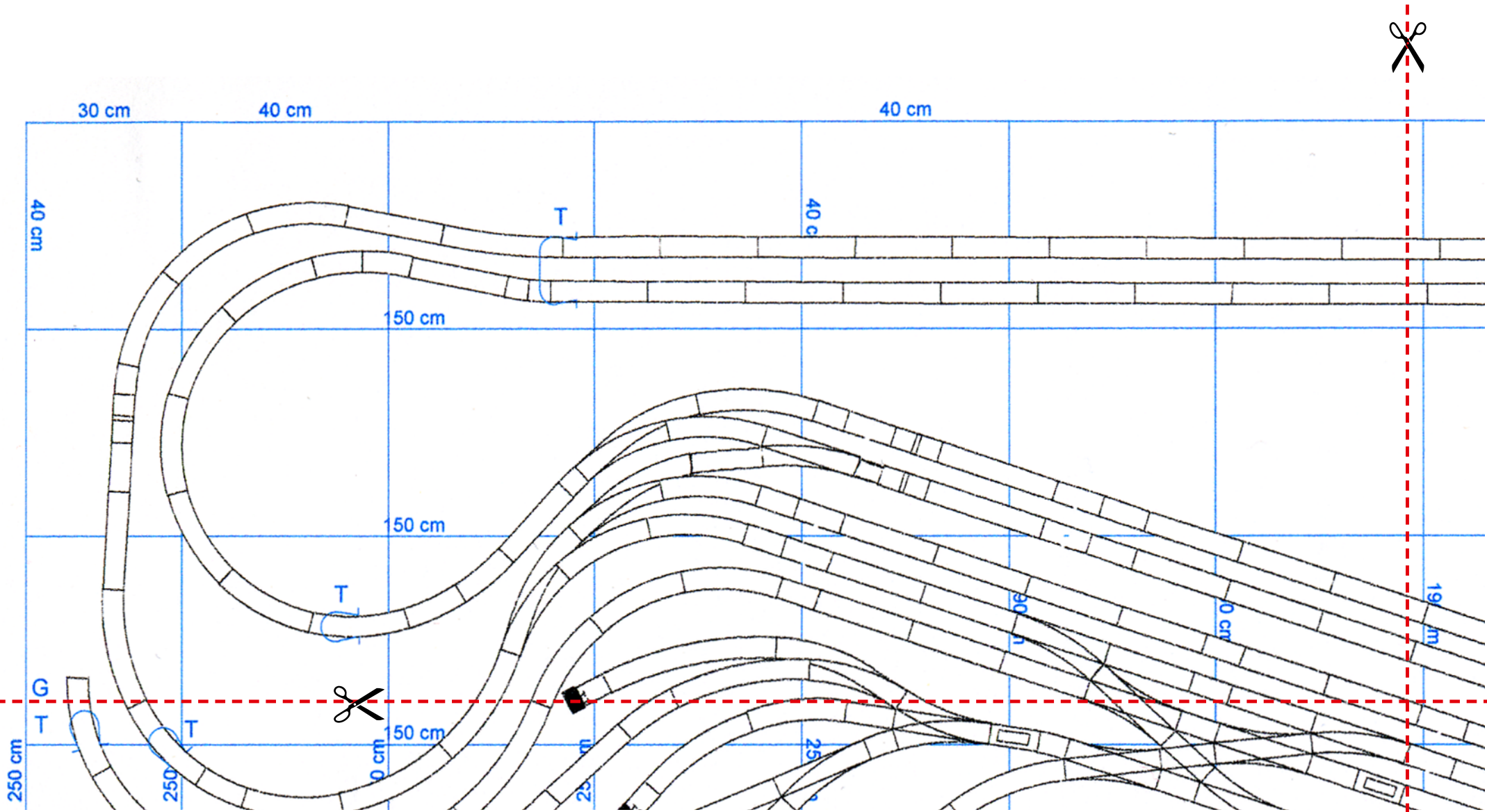

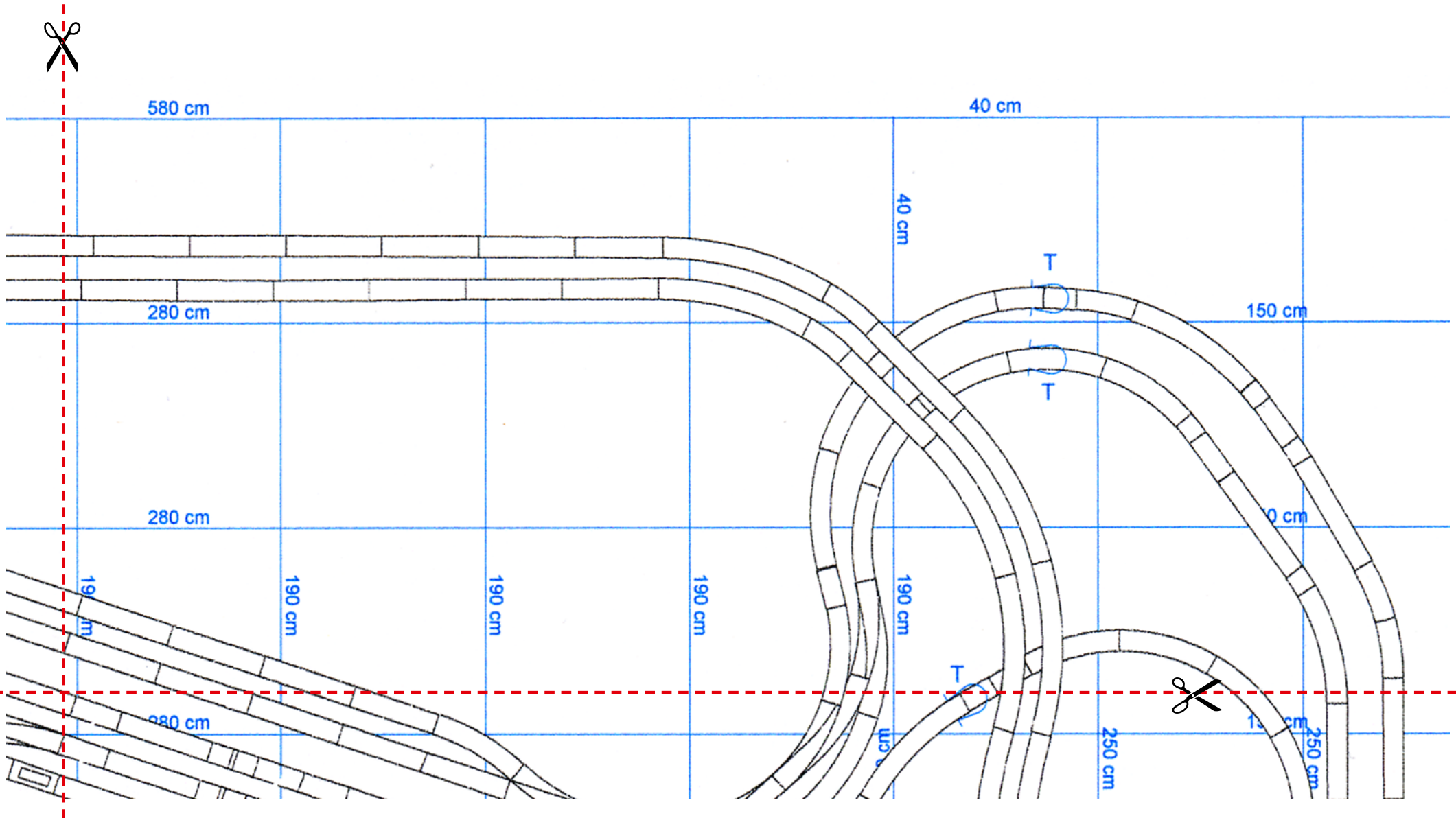

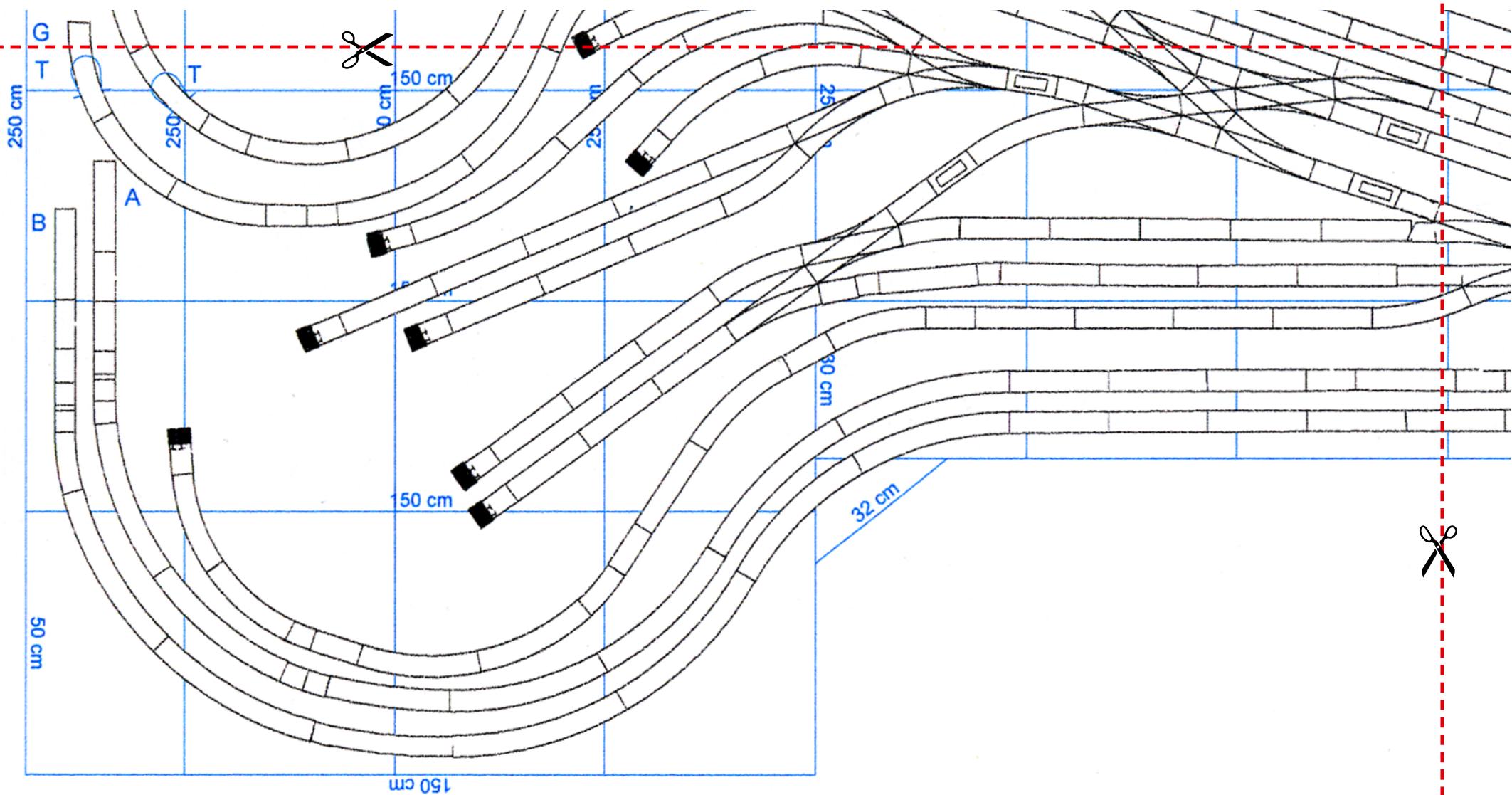

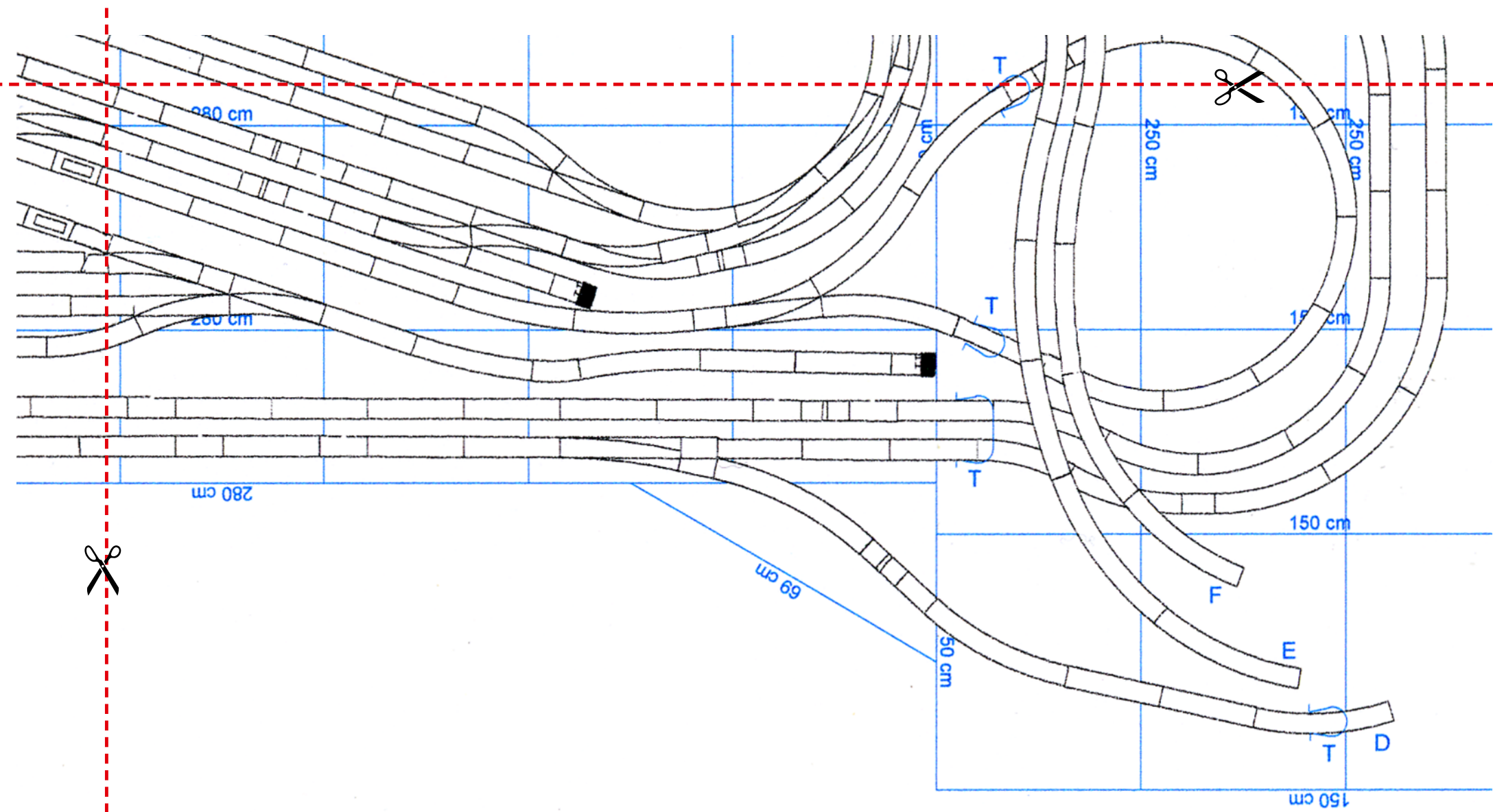

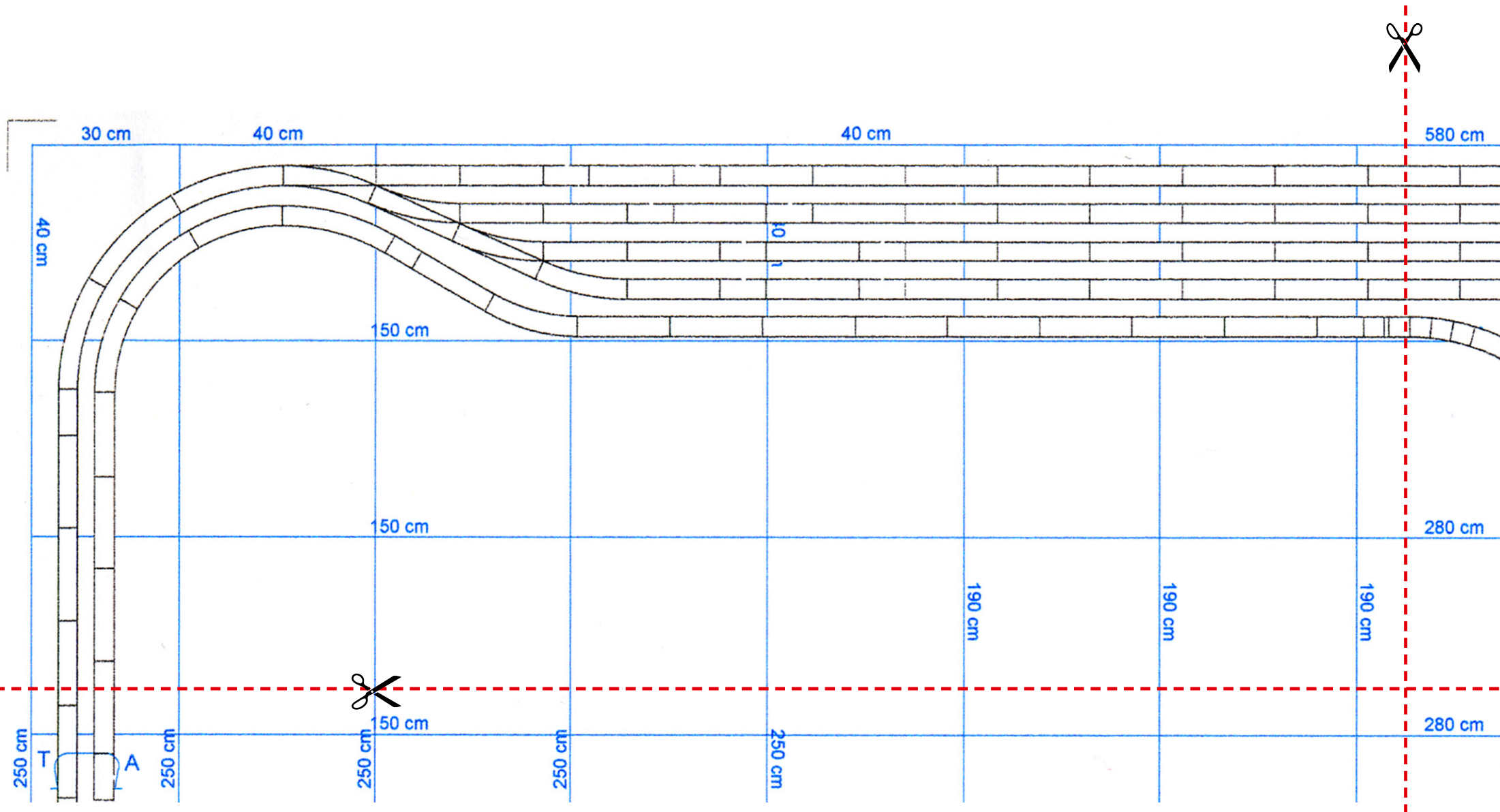

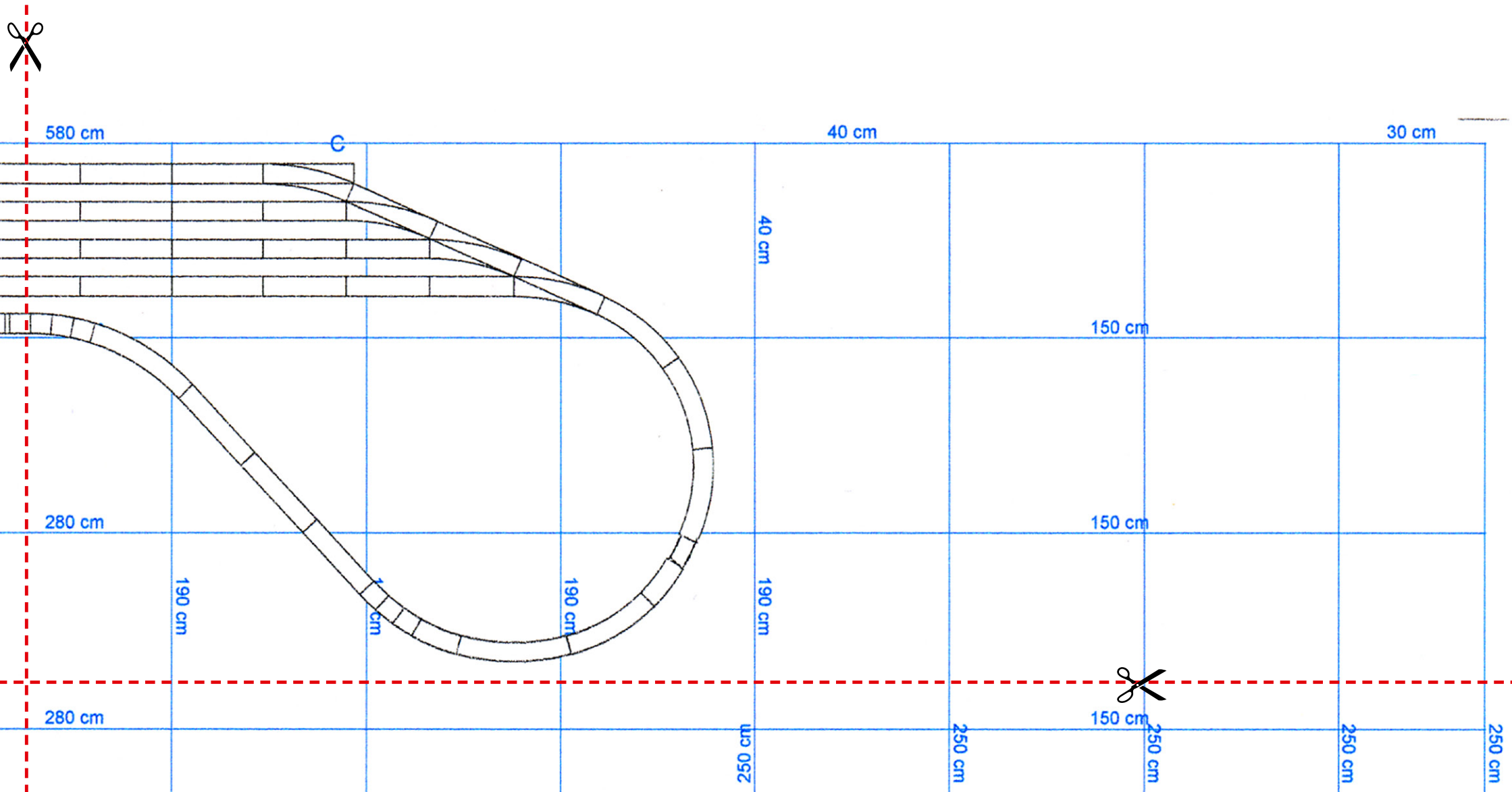

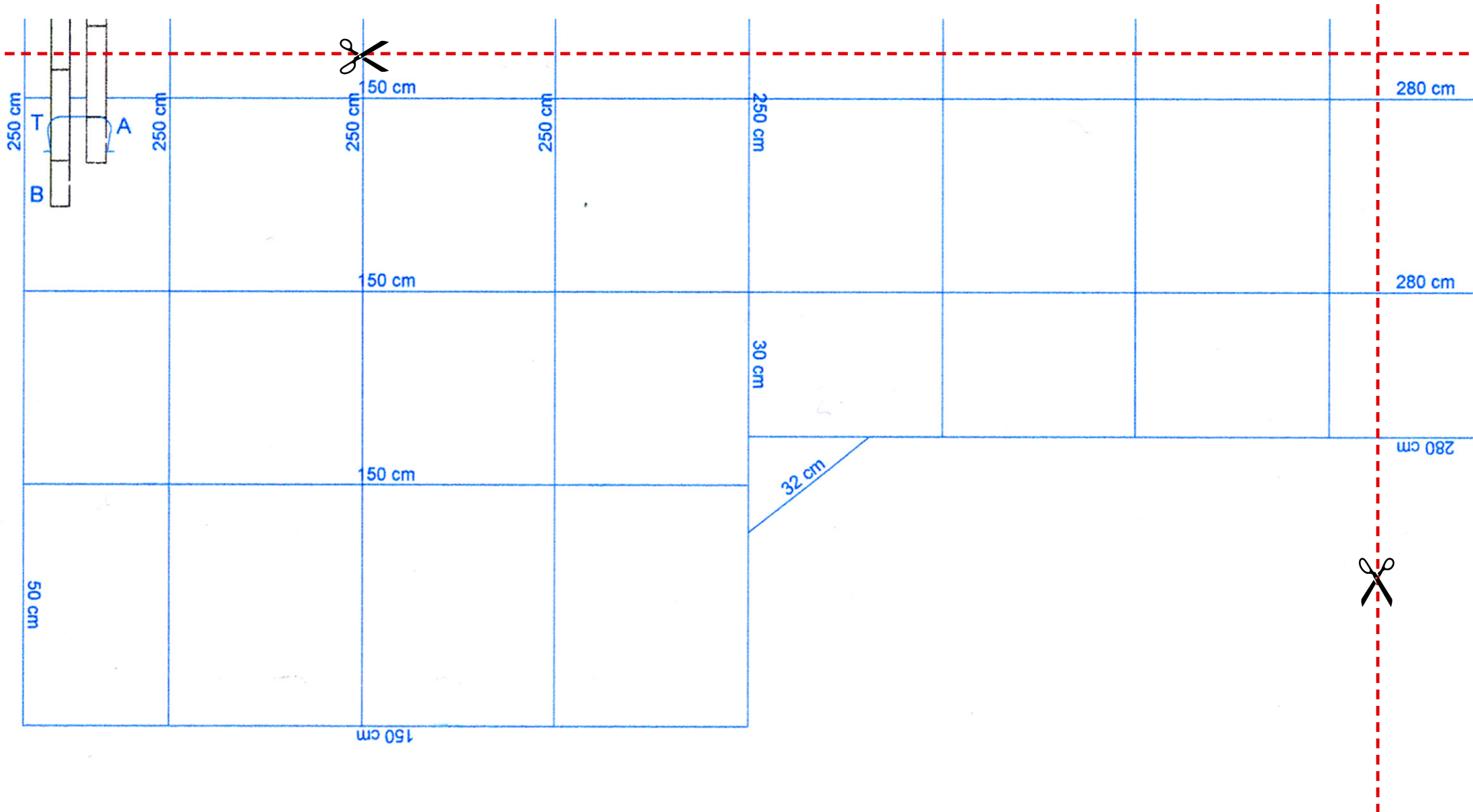

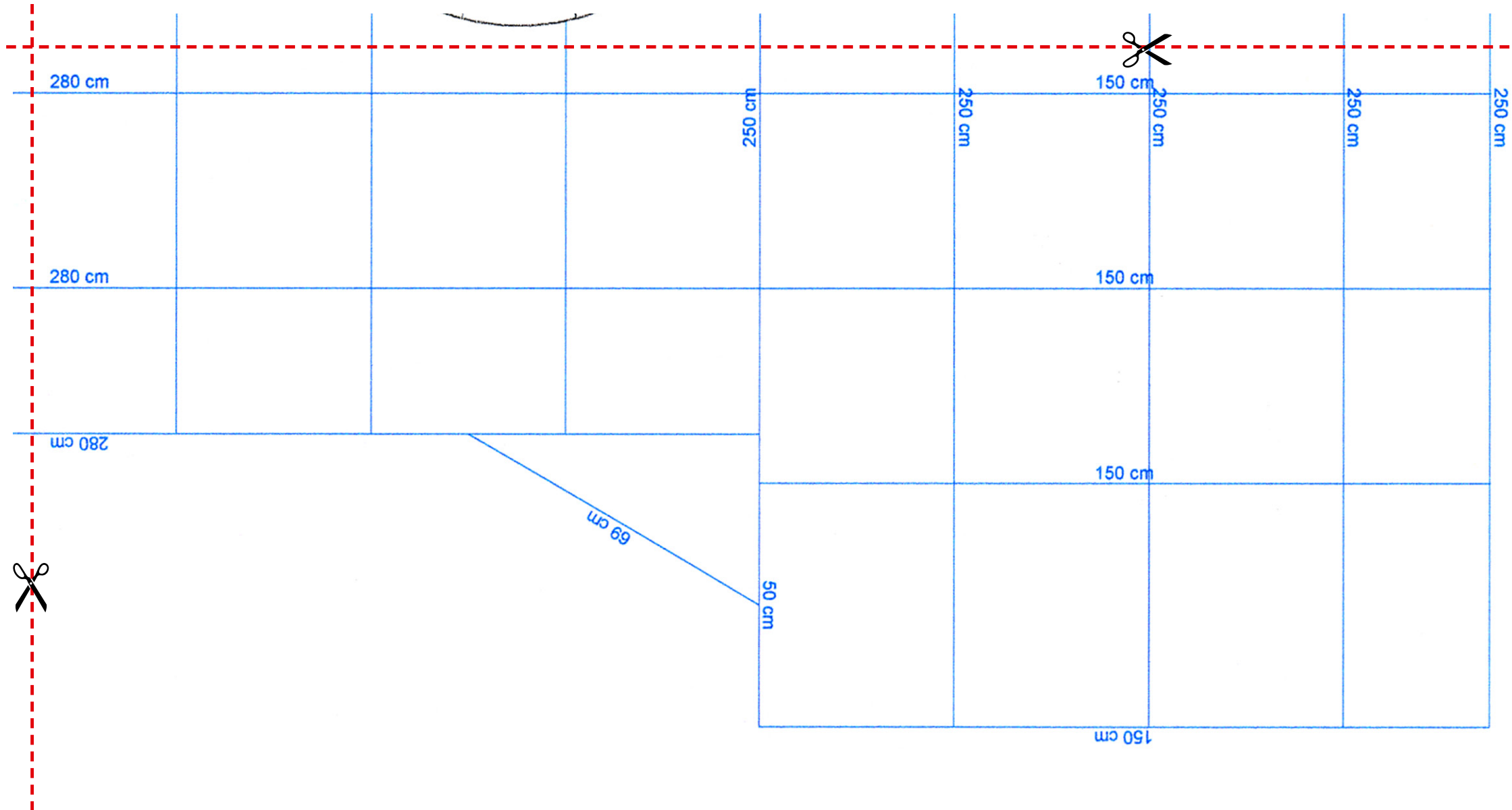

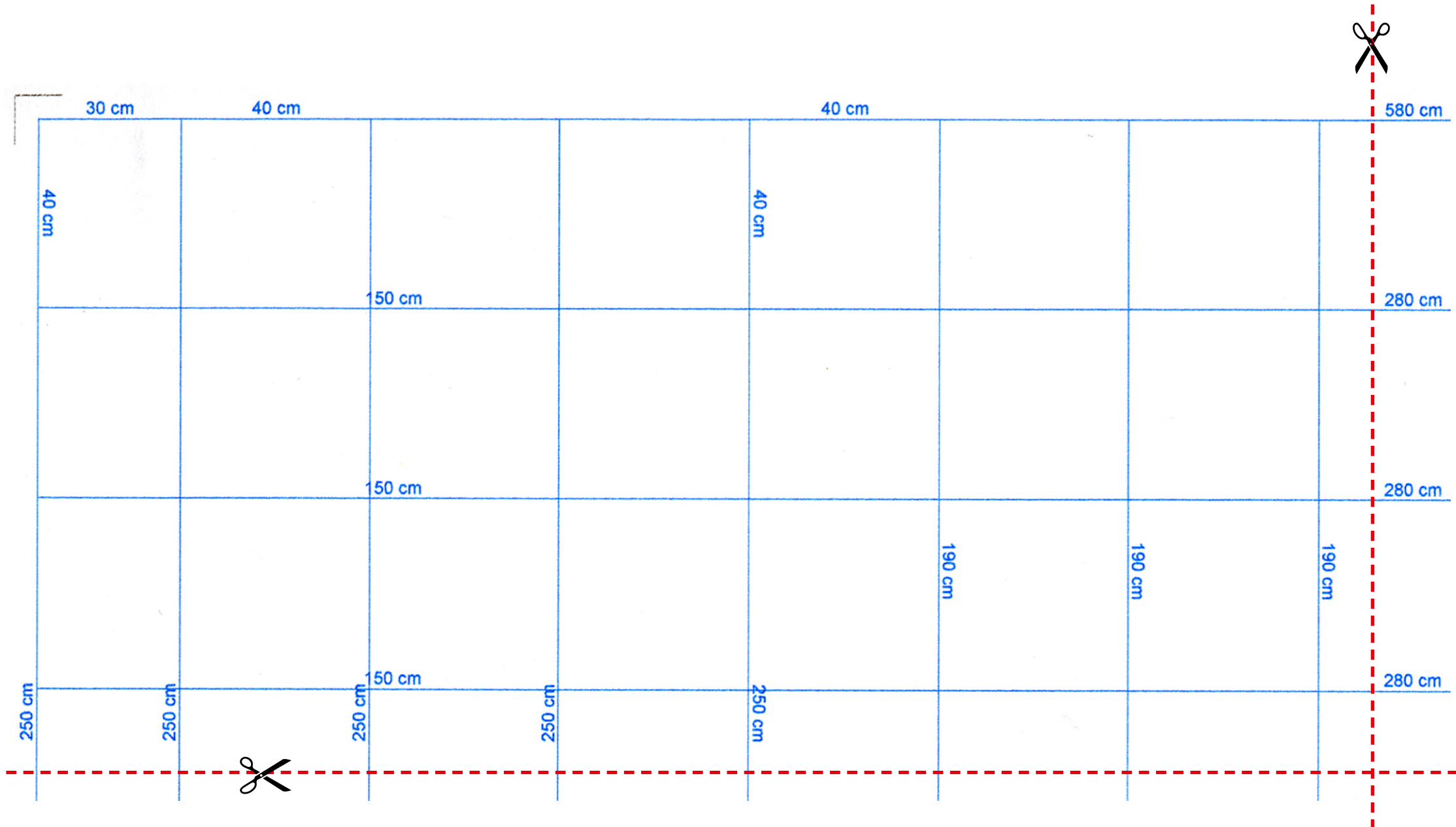

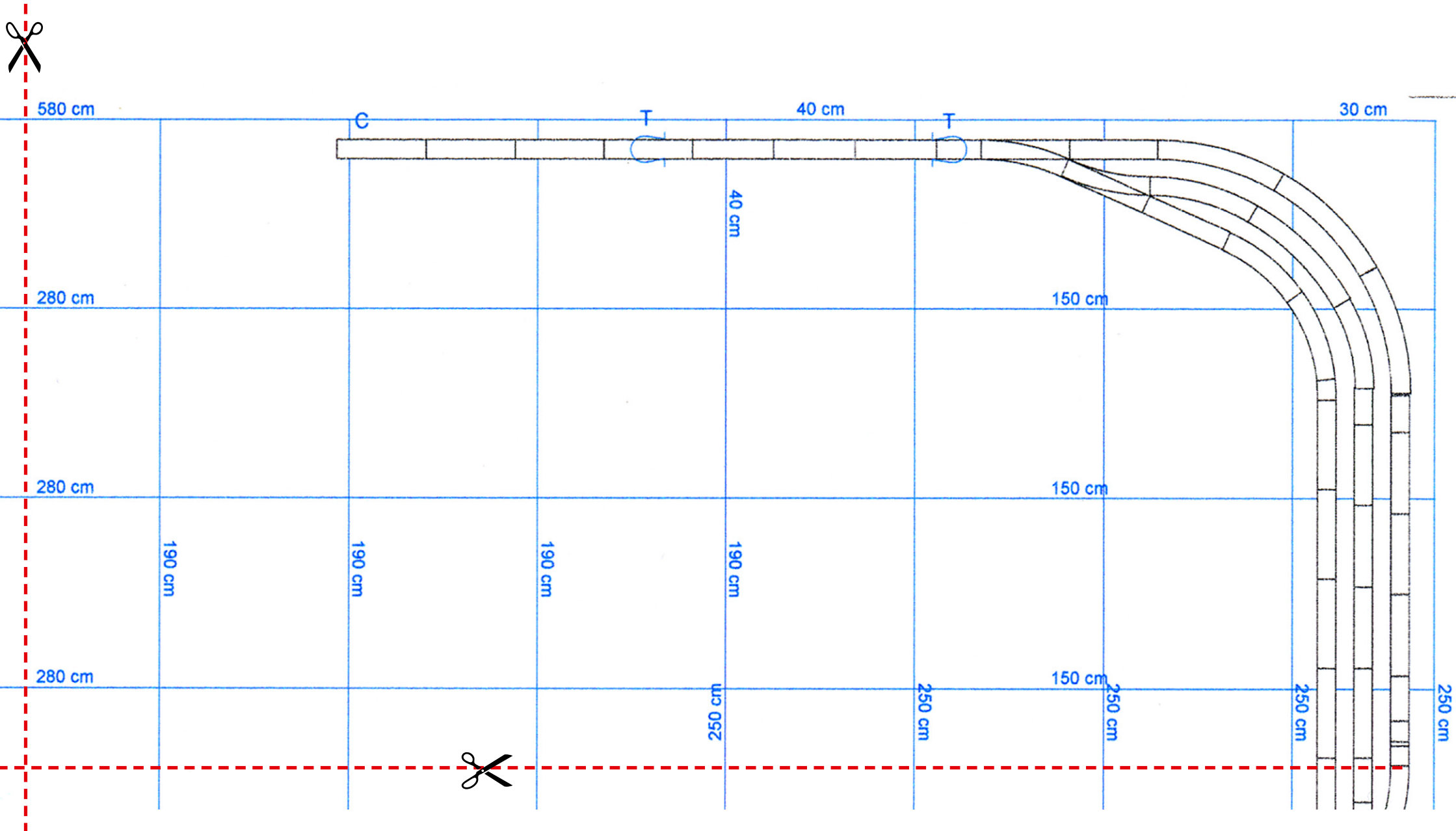

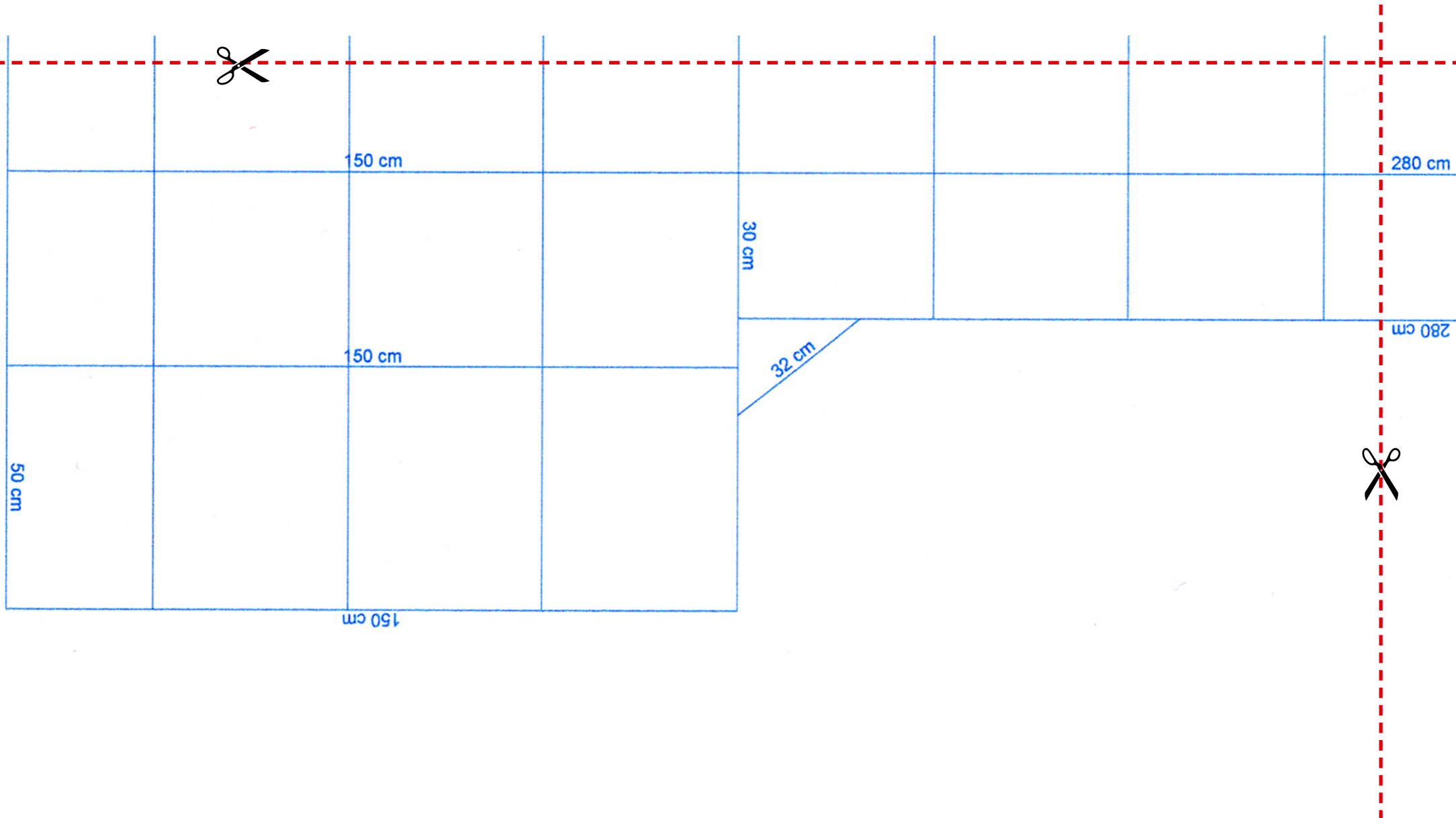

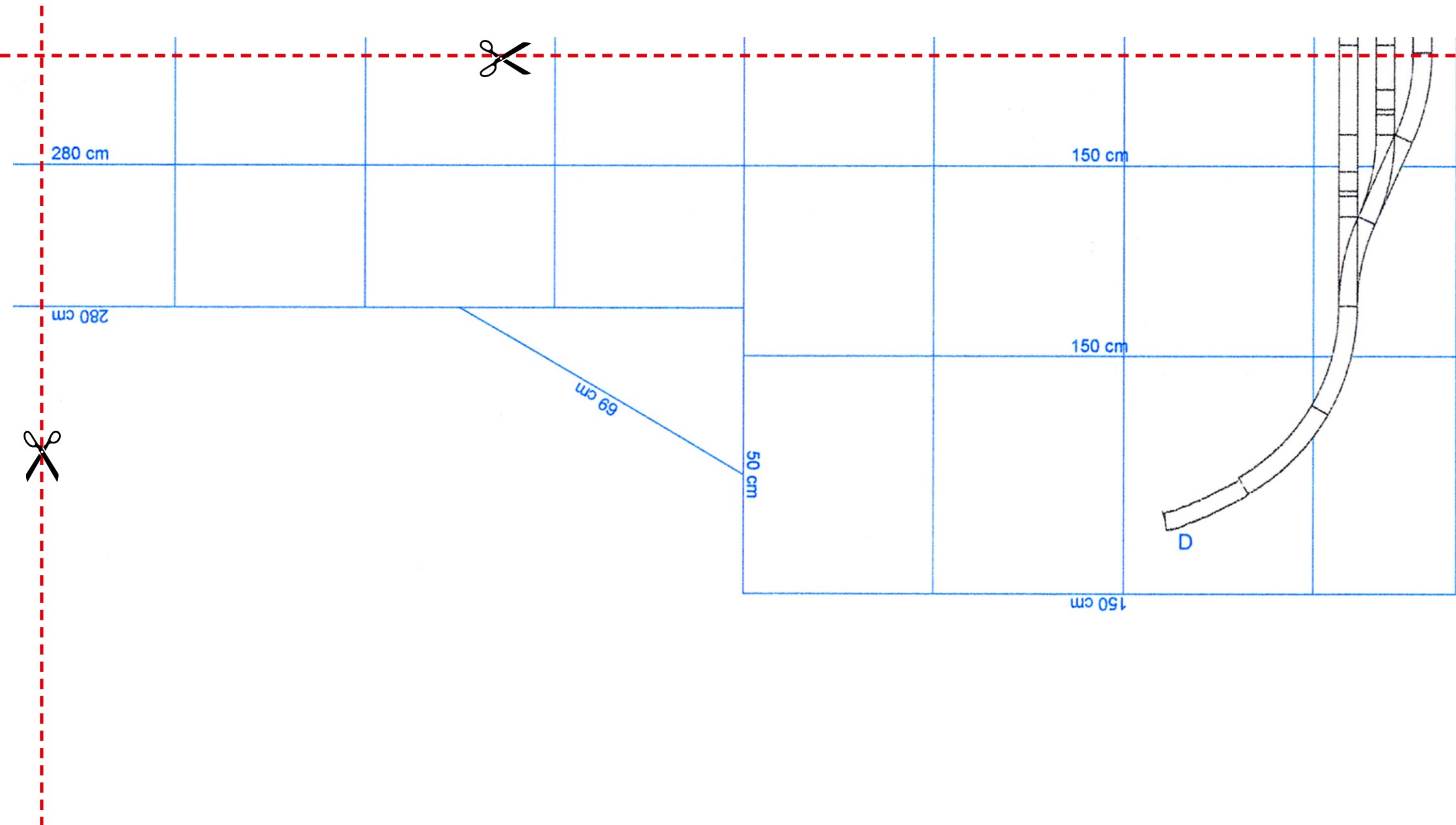

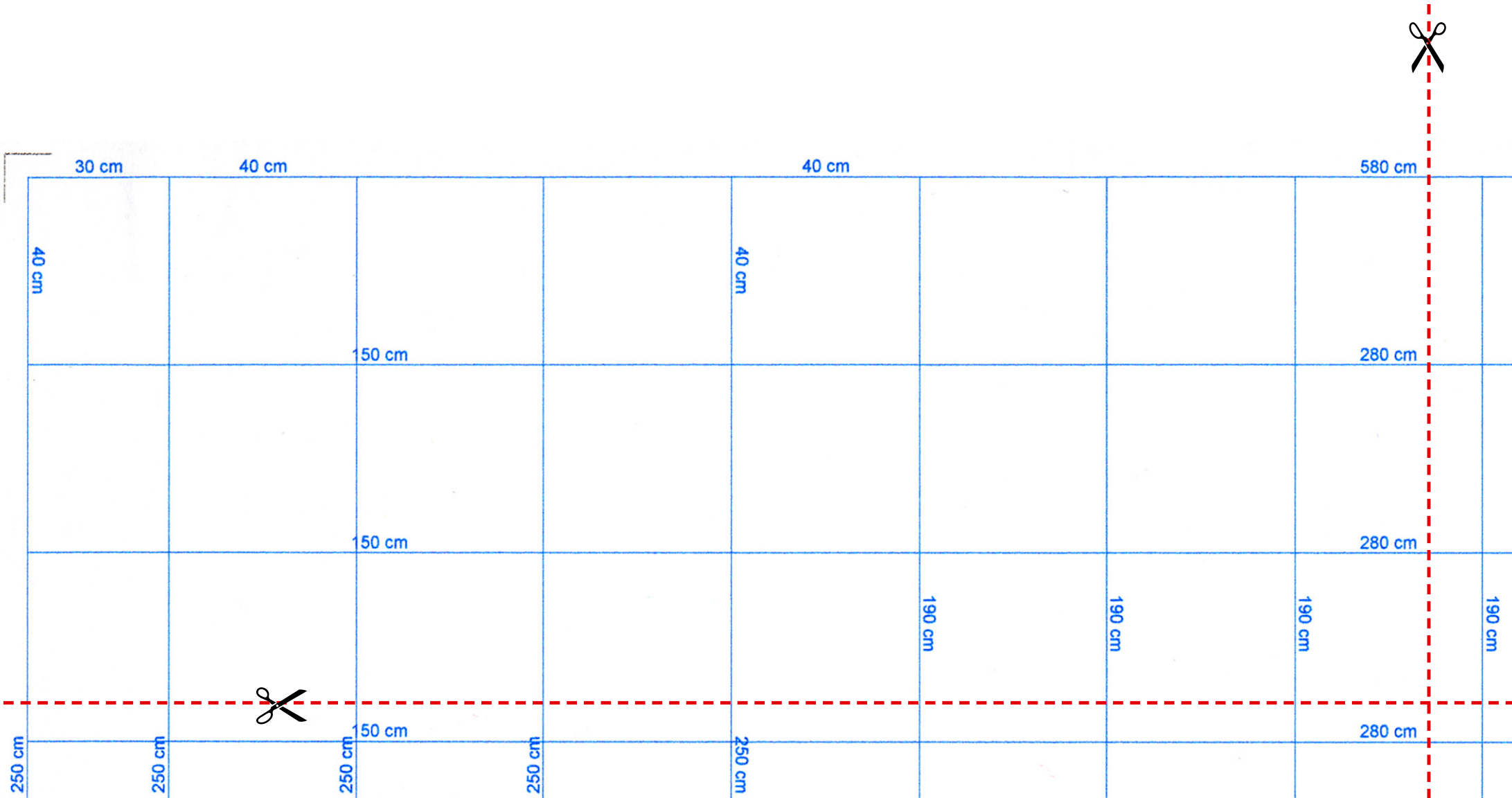

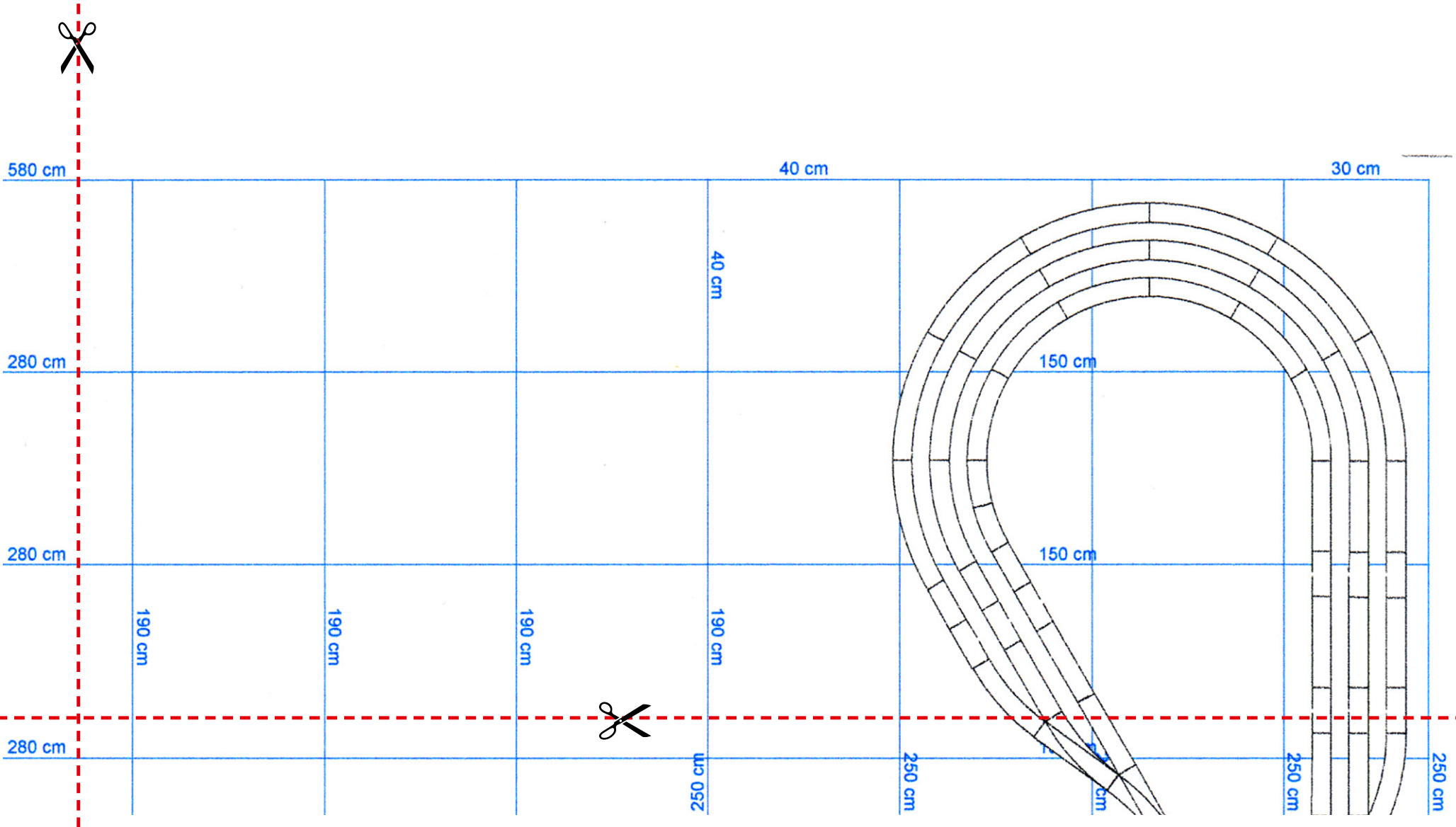

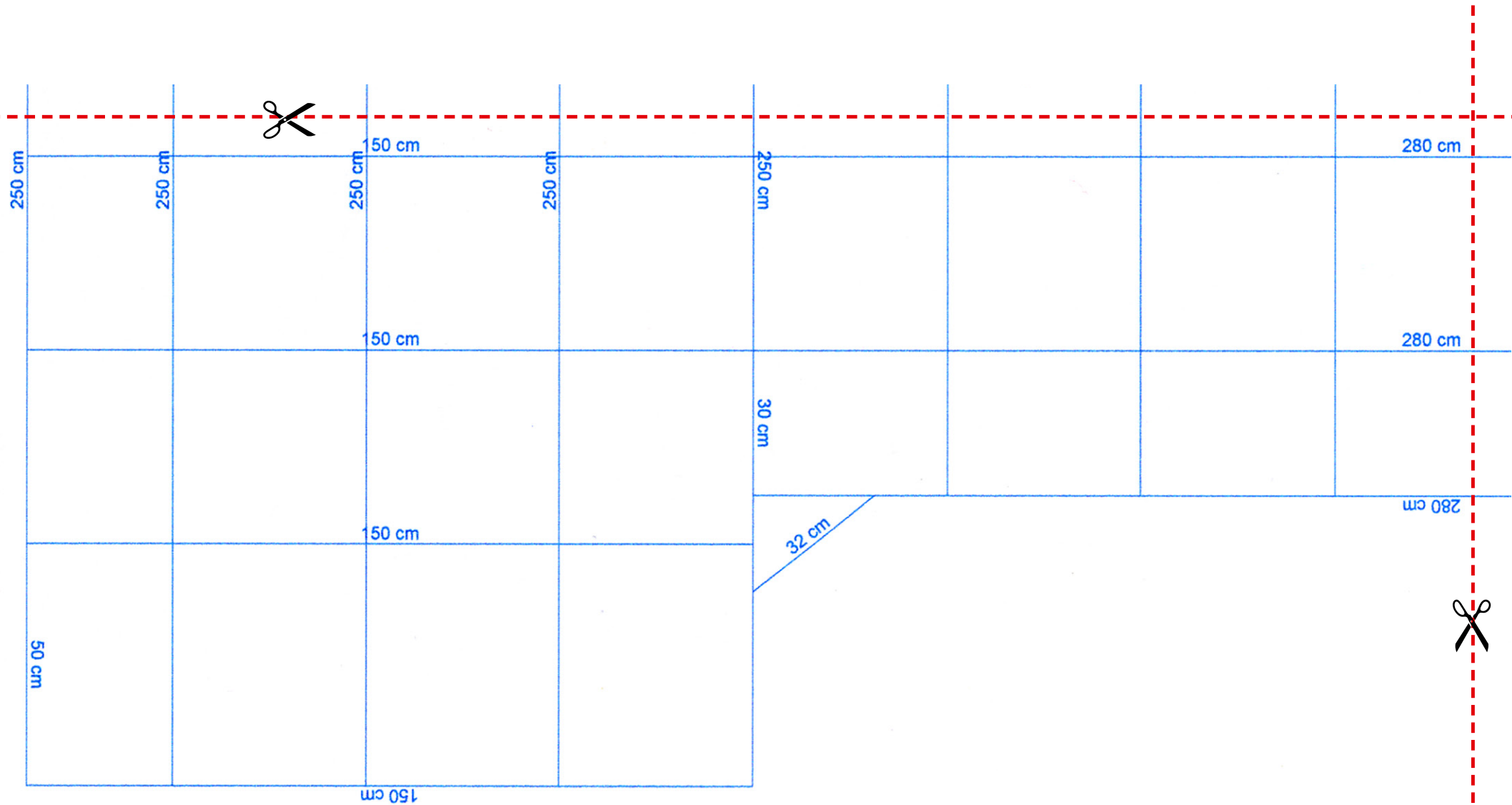

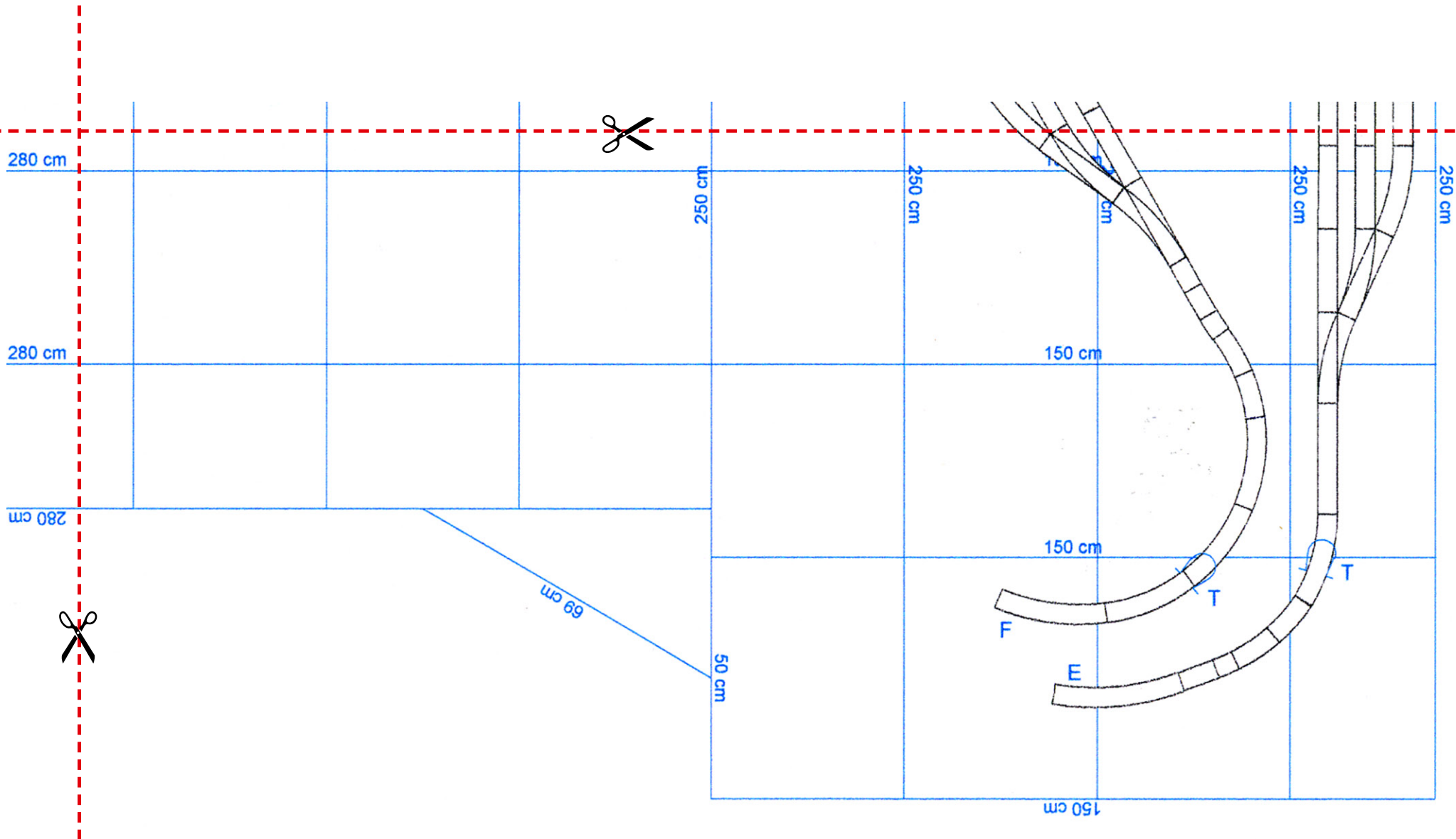

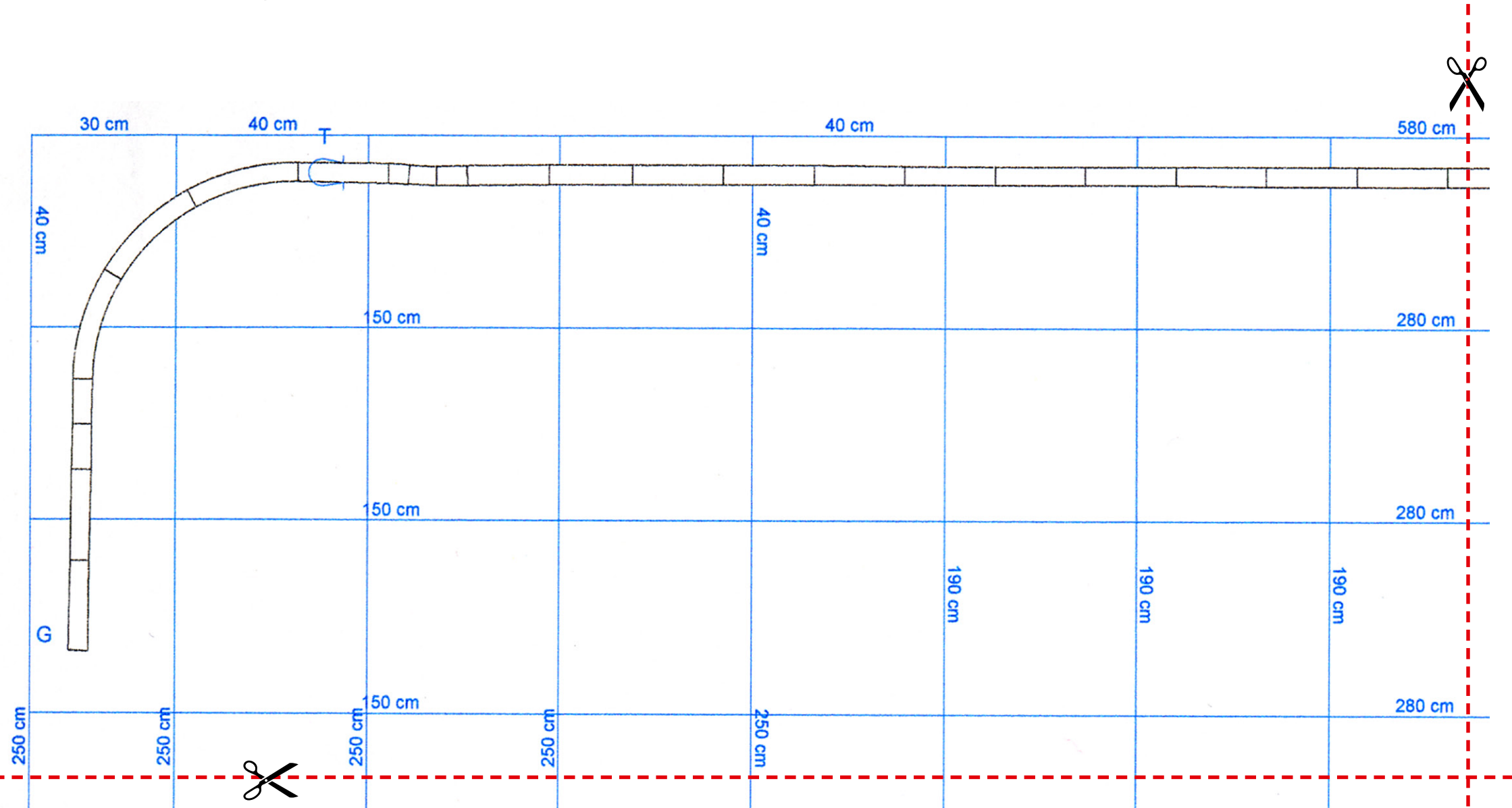

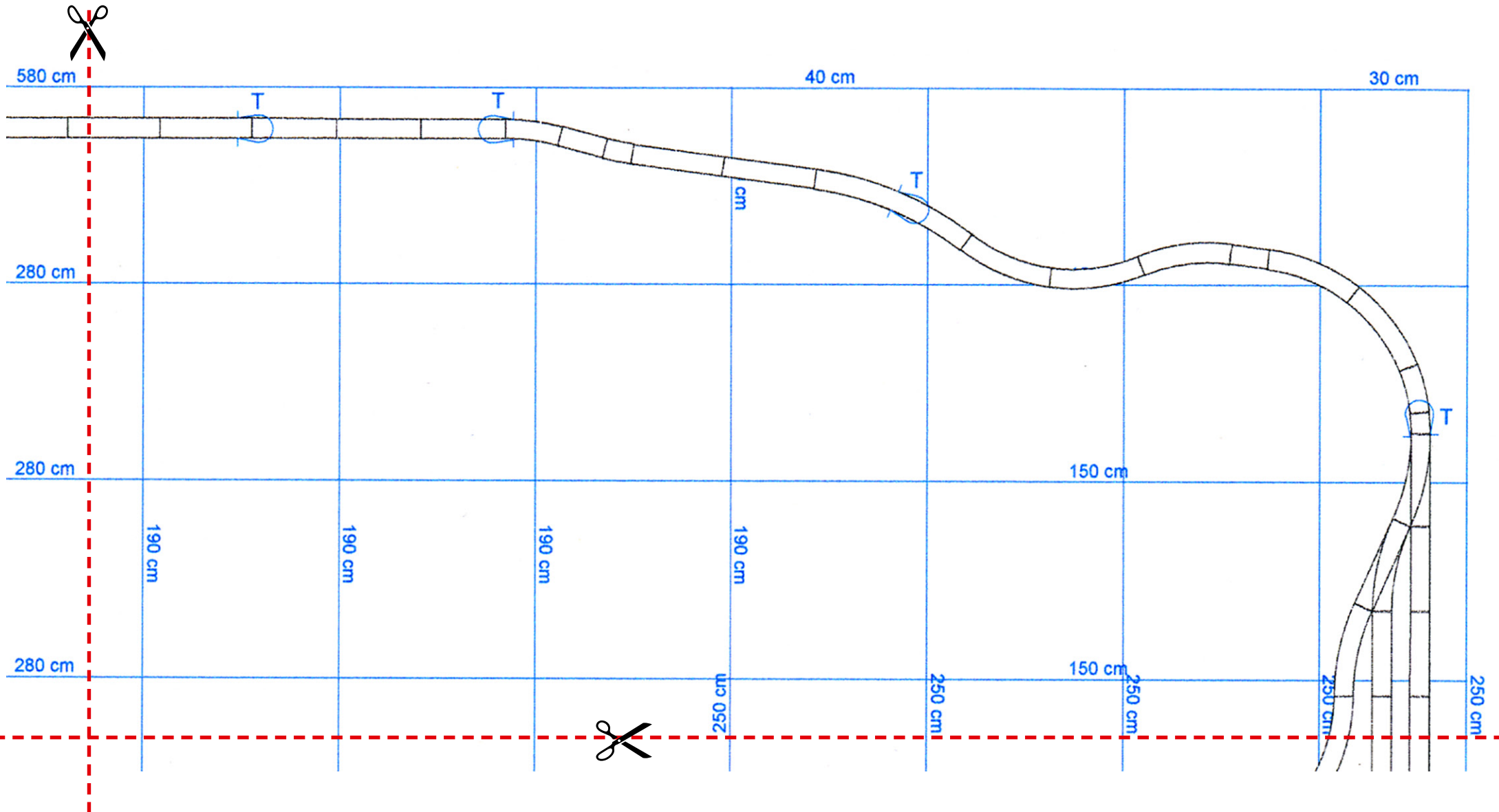

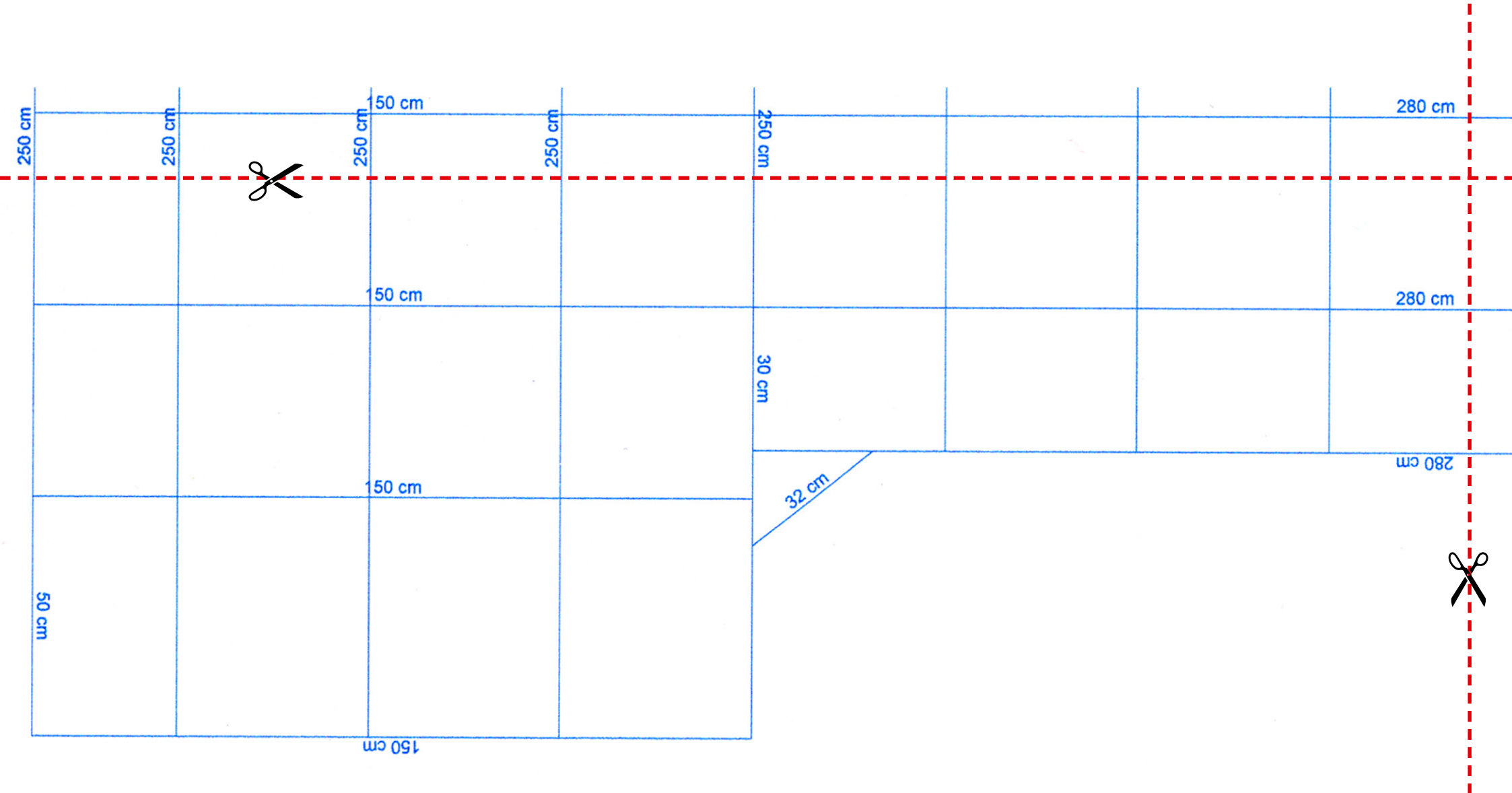

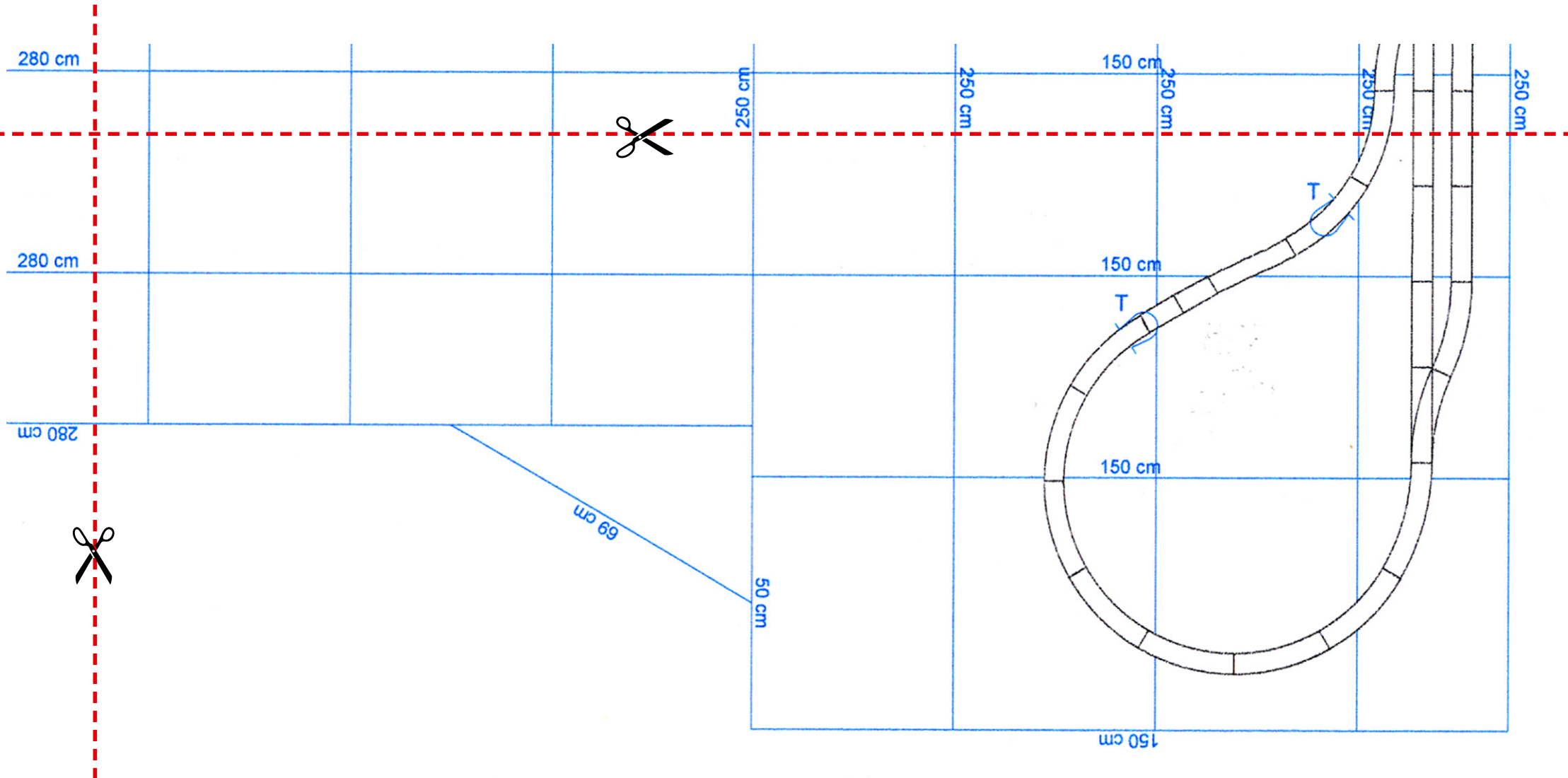

- 1 Hauptbahnhof Freiberg
- 2 Großes Dampflok-Betriebswerk mit Drehscheibe und Rundlokschuppen
- 3 Bahnsteige
- 4 Post mit Verladegleis
- 5 Lagerhauskomplex 1 und 2
- 6 Stadthäuser
- 7 Wasserhaus
- 8 Nebenbahnhof Neukloster
- 9 Burgruine
- 10 Schloss Lichtenstein

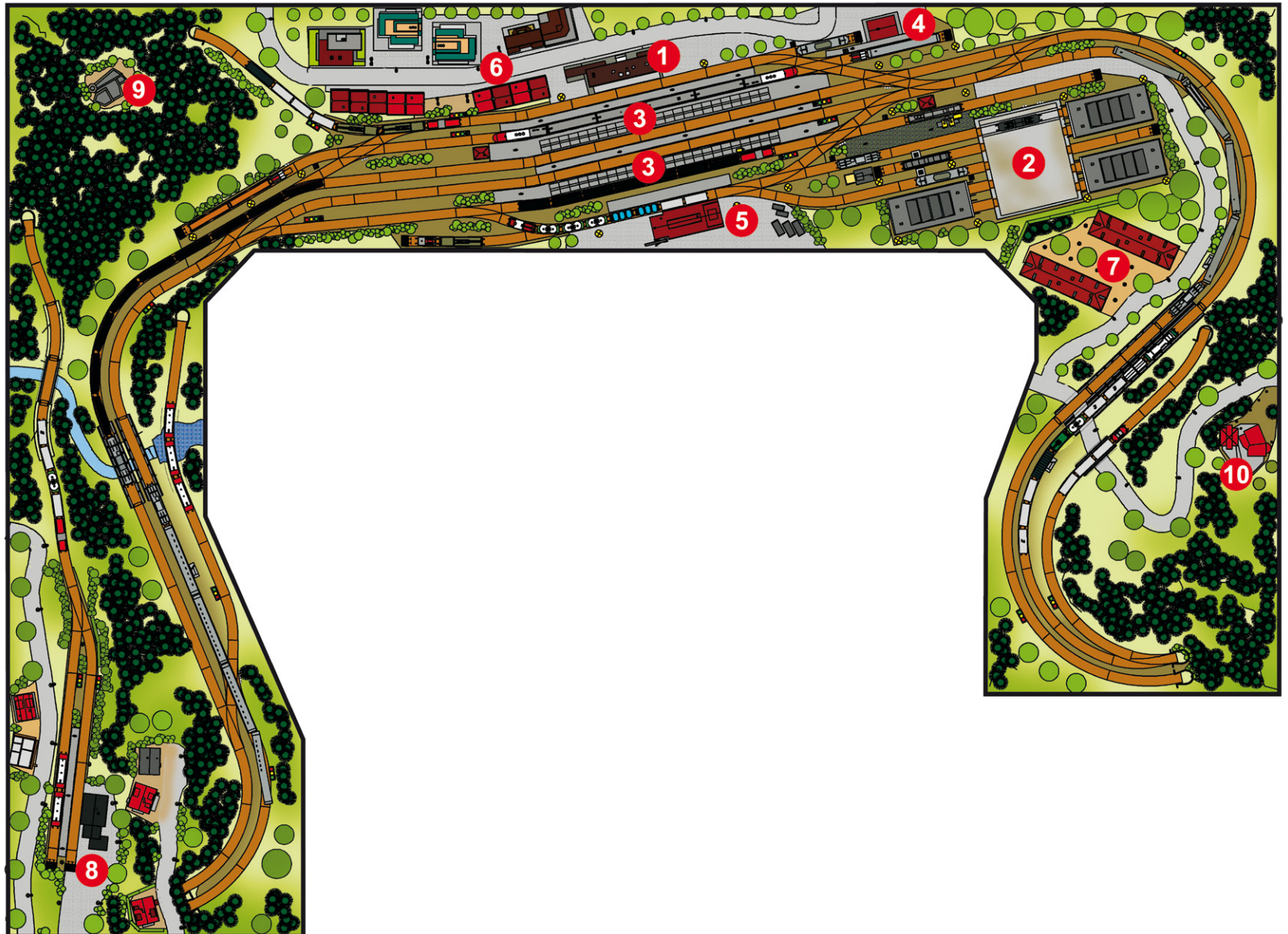

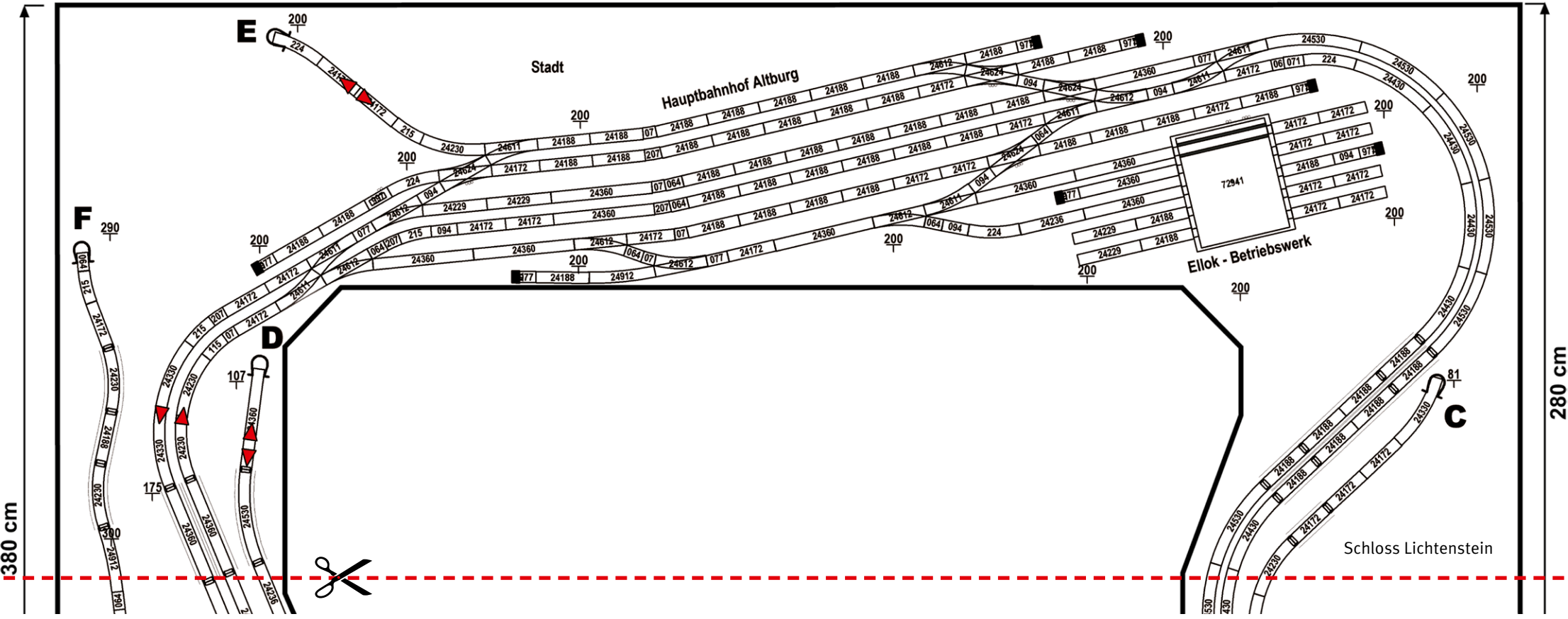

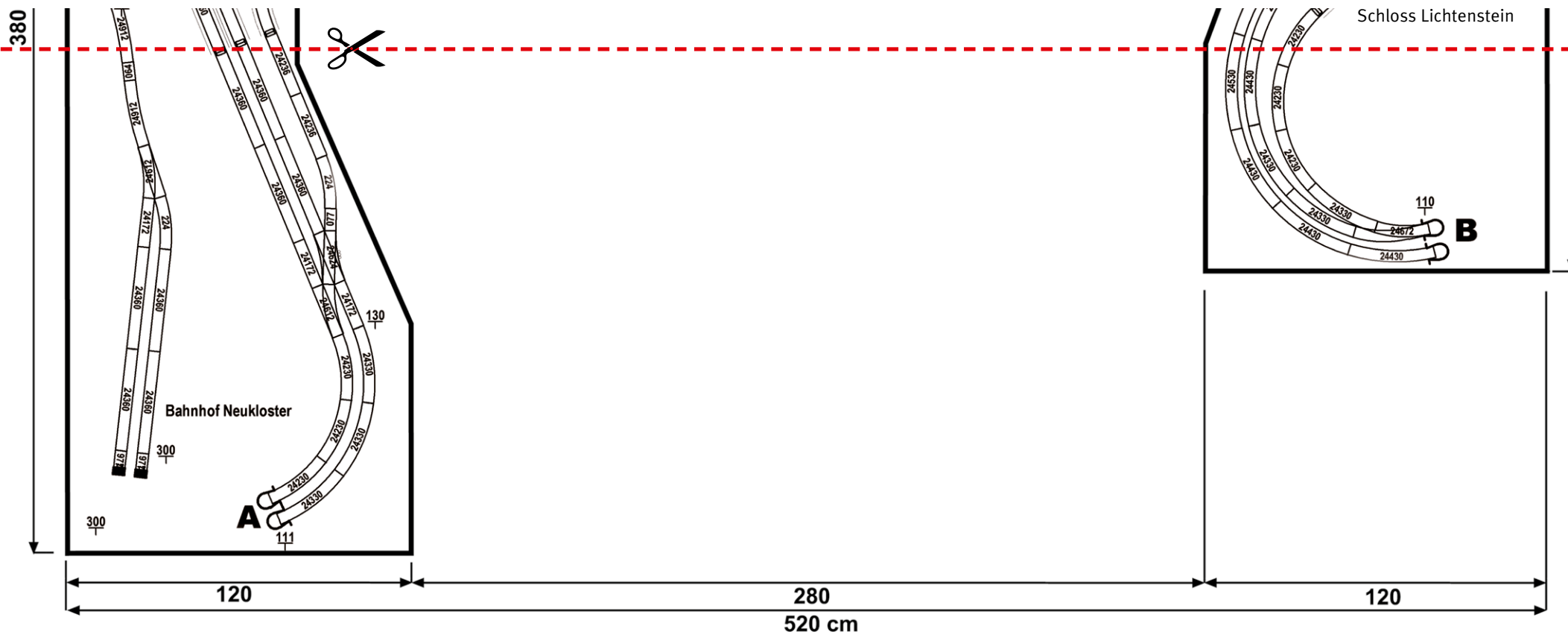

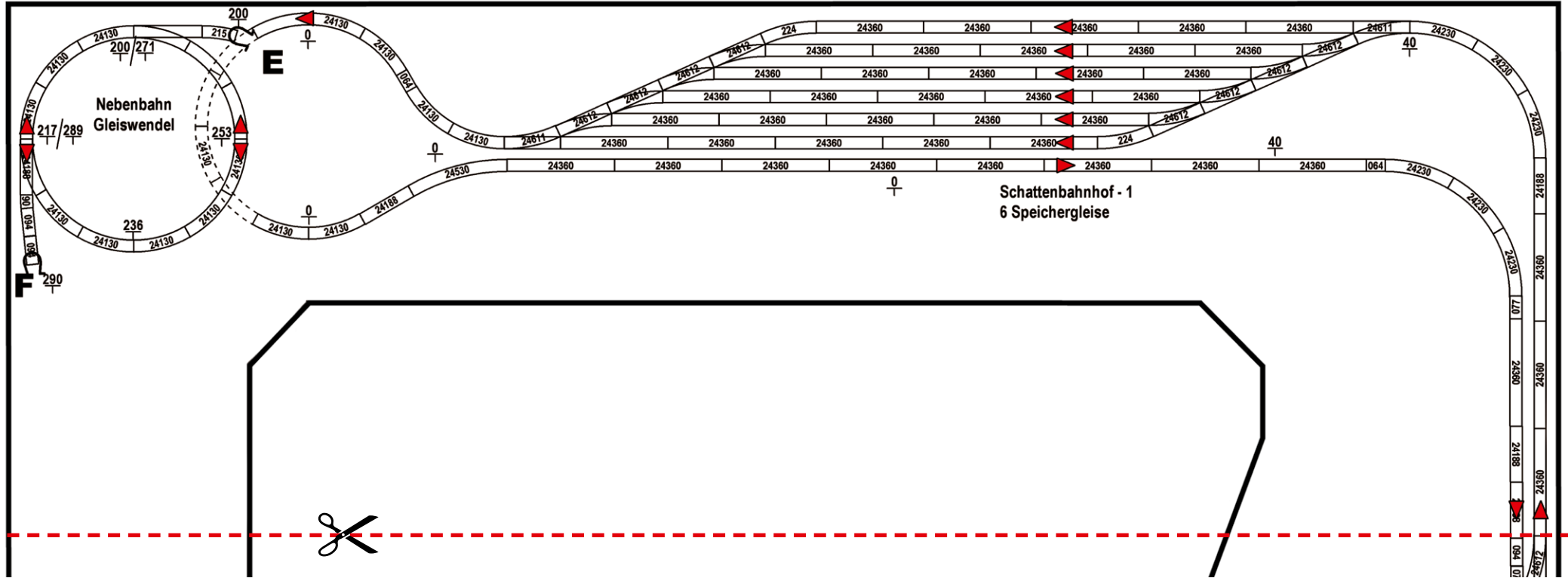

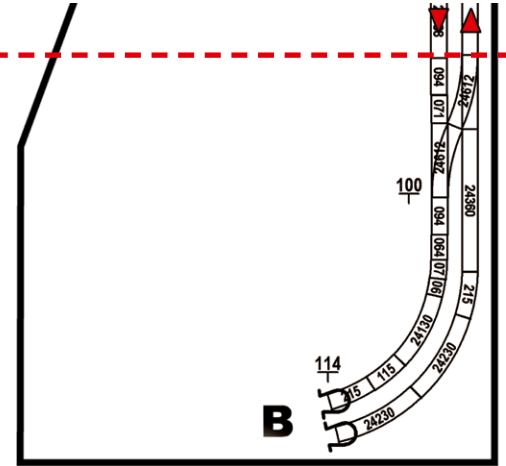
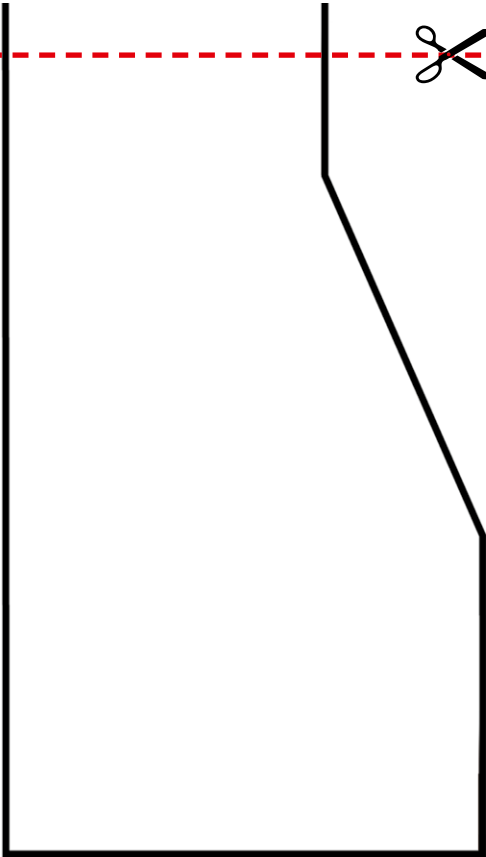

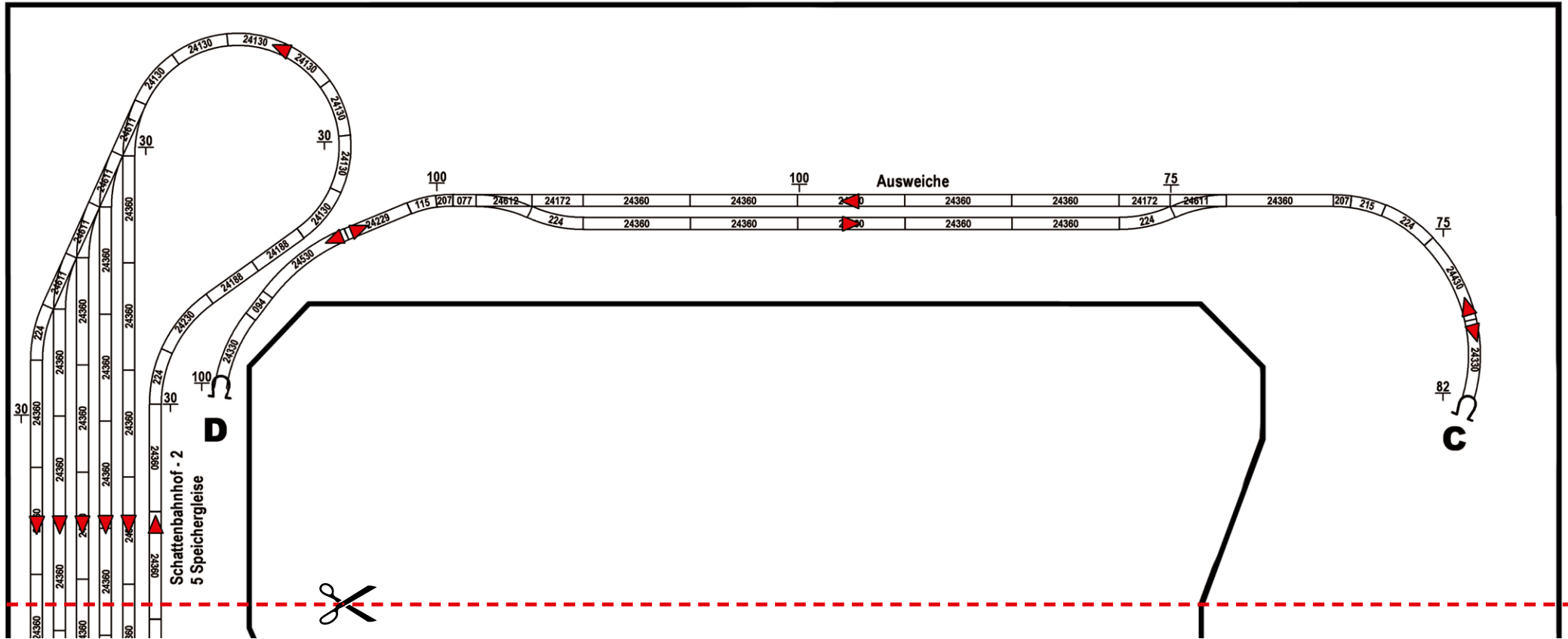

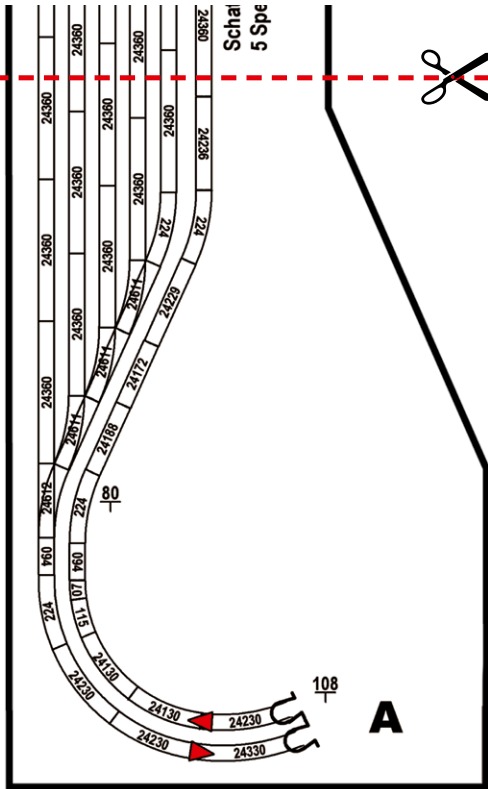

- 1 Hauptbahnhof Freiberg
- 2 Großes Dampflok-Betriebswerk mit Drehscheibe und Rundlokschuppen
- 3 Bahnsteige
- 4 Post mit Verladegleis
- 5 Lagerhauskomplex 1 und 2
- 6 Stadthäuser
- 7 Wasserhaus
- 8 Nebenbahnhof Neukloster
- 9 Burgruine
- 10 Schloss Lichtenstein

